



MULTIPOISE, CONDENSING

58MCA, 58MVP, 58MXA

GAS FURNACE

USER'S INFORMATION MANUAL FOR THE OPERATION AND MAINTENANCE OF YOUR NEW GAS-FIRED FURNACE

**NOTE TO INSTALLER:
THIS MANUAL MUST BE LEFT WITH THE
EQUIPMENT USER.**

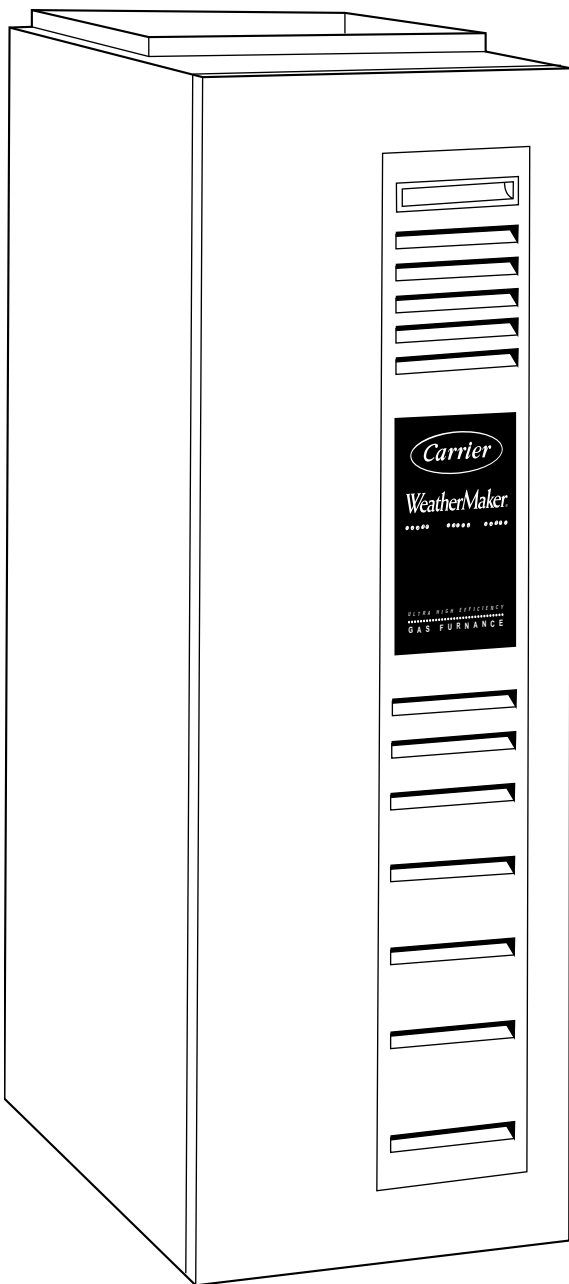

WARNING: If the information in this manual is not followed exactly, a fire or explosion may result causing property damage, personal injury or loss of life.

- Do not store or use gasoline or other flammable vapors and liquids in the vicinity of this or any other appliance.
- **WHAT TO DO IF YOU SMELL GAS:**
 - Do not try to light any appliance.
 - Do not touch any electrical switch; do not use any phone in your building.
 - Immediately call your gas supplier from a neighbor's phone. Follow the gas supplier's instructions.
 - If you cannot reach your gas supplier, call the fire department.
- Installation and service must be performed by a qualified installer, service agency or the gas supplier.

WELCOME TO A NEW GENERATION OF COMFORT

Congratulations! In light of rising energy costs, the Weather-Maker® 9200, 58MCA, and WeatherMaker Infinity, Multi-poise, Gas-Fired Condensing Furnaces are among the soundest investments today's homeowner can make.

Your new furnace is truly a triumph of technology in home heating. A revolutionary design employs 2 heat exchangers to "squeeze" out the maximum amount of heat from the fuel consumed. In fact, your new furnace is so efficient, over 90%* of the heat generated during combustion is captured and delivered inside your home. That is more than a 33%* increase in heating efficiency over conventional furnaces.

These are among the most energy-efficient furnaces you can buy today. They also are among the safest and most dependable. We are proud of the technological advances incorporated into the design of these furnaces. With only minimal care, your new furnace will deliver many years of money-saving home comfort and enjoyment. Spend just a few minutes with this manual to learn the operation of your new furnace and the small amount of maintenance it takes to help keep it operating at peak efficiency year after year.

* The output capacity and any representations of efficiency for this furnace are based on standard Department of Energy test procedures.

INSTALLATION DATA

Date Installed _____

Dealer Name _____

Address _____

City _____

State _____ Zip _____

Telephone _____

FURNACE

Product No. _____

Model No. _____

Serial No. _____

SPLIT-SYSTEM

Product No. _____

Model No. _____

Serial No. _____

INDOOR COIL:

Product No. _____

Model No. _____

Serial No. _____

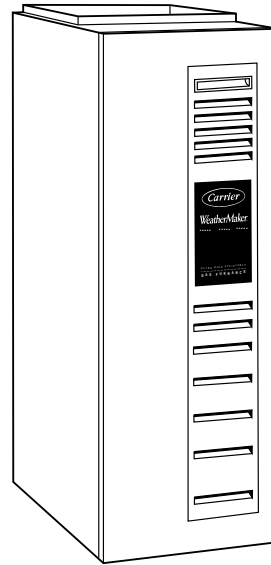

MODELS 58MXA (SHOWN) AND 58MCA FIXED-CAPACITY FURNACES

1

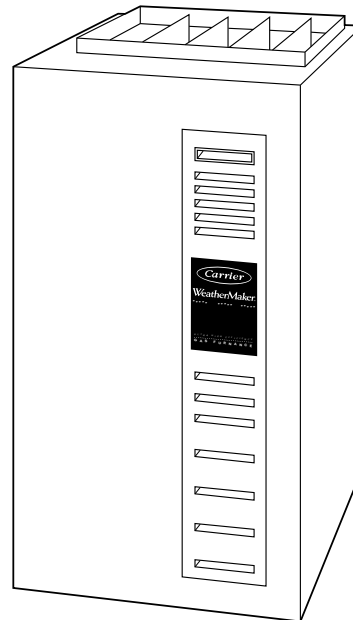

MODEL 58MVP VARIABLE-CAPACITY FURNACE

2

FURNACE COMPONENTS

- 1 Combustion-air intake connection to ensure contaminant-free air (right or left side).
- 2 Burner sight glass for viewing burner flame.
- 3 Burner assembly (inside). Operates with energy-saving inshot burners and hot surface ignitor for safe, dependable heating.
- 4 Redundant gas valve. Safe, efficient. Features 1 gas control with 2 internal shut-off valves.
- 5 Vent outlet. Uses PVC pipe to carry vent gases from the furnace's combustion system (right or left side).
- 6 Inducer motor. Pulls hot flue gases through the heat exchangers, maintaining negative pressure for added safety.
- 7 Blower access panel safety interlock switch.
- 8 Air filter and retainer.
- 9 Condensate drain connection. Collects moisture condensed from burned gases for disposal into home drain system.
- 10 Heavy-duty blower. Circulates air across the heat exchangers to transfer heat into the home.
- 11 Secondary condensing heat exchanger (inside). Wrings out more heat through condensation. Constructed with Polypropylene-laminated steel to ensure durability.
- 12 Primary serpentine heat exchanger (inside). Stretches fuel dollars with the S-shaped heat-flow design. Solid construction of corrosion-resistant aluminized steel means reliability.
- 13 Control center.
- 14 3-amp fuse provides electrical and component protection.
- 15 Light emitting diode (LED) on control center. Code lights are for diagnosing furnace operation and service requirements.
- 16 Pressure switch(s) ensure adequate flow of flue products through furnace and out vent system.
- 17 Rollout switch (manual reset) to prevent overtemperature.
- 18 Junction box for 115-v electrical power supply.
- 19 Transformer (24v) behind control center provides low-voltage power to furnace control center and thermostat.
- 20 Limit switch (manual reset) on 58MVP only.

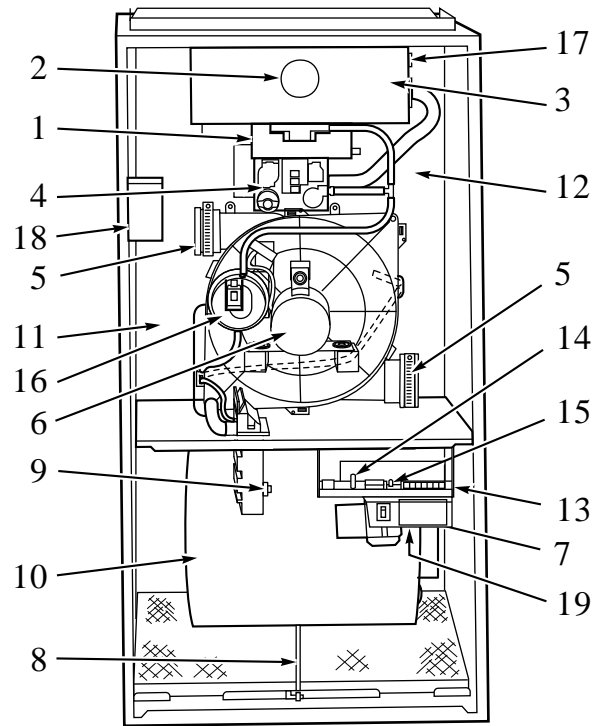

3

MODELS 58MXA AND 58MCA FURNACES (UPFLOW POSITION)

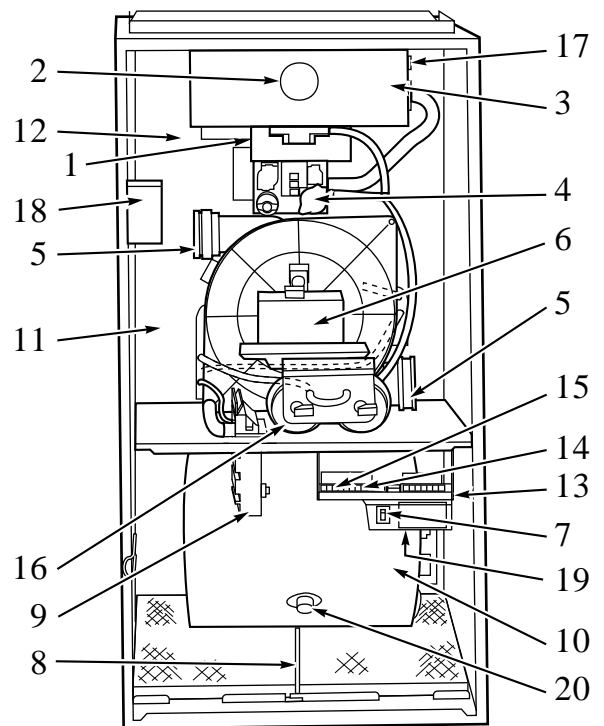

4

MODEL 58MVP FURNACE (UPFLOW POSITION)

IMPORTANT FACTS

Your gas furnace uses air from outside the home for combustion and venting. It is not to be installed using in-house air. Therefore, both pipes must terminate outside the structure and must not be obstructed in any way.

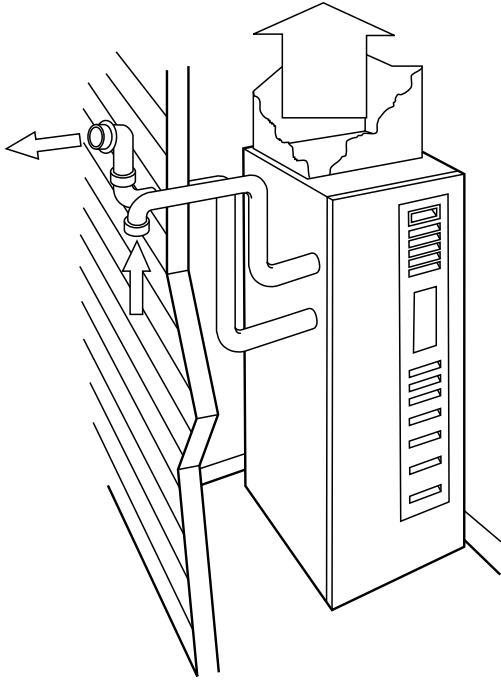

5

To minimize the possibility of serious personal injury, fire, damage to your furnace, or improper operation, **carefully follow these safety rules:**

- Keep the area around your furnace free of combustible materials, gasoline, and other flammable liquids and vapors.
- Do not cover the furnace, store trash or debris near it, or in any way block the flow of fresh air to the unit.
- A furnace installed in an attic or other insulated space must be kept free and clear of insulating material. Examine the furnace area when installing the furnace or adding more insulation. Some materials may be combustible.

NOTE: Do not use this furnace if any part has been under water. Immediately call a qualified service technician to inspect the furnace and to replace any part of the control system and any gas control which has been under water.

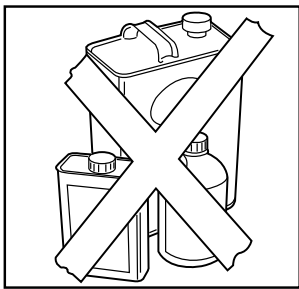

NOTE: The qualified installer or agency must use only factory-authorized replacement parts, kits, and accessories when modifying this product.

6

This furnace contains SAFETY DEVICES which must be MANUALLY RESET. If the furnace is left unattended for an extended period of time, have it checked periodically for proper operation. This precaution will prevent problems associated with no heat, such as frozen water pipes, etc. See section "Before You Request a Service Call" in this manual.

SAFETY CONSIDERATIONS

Installation and service of heating equipment can be hazardous due to gas and electrical components. Only trained and qualified personnel should install, repair, or service heating equipment.

Untrained personnel can perform basic maintenance functions such as cleaning and replacing air filters. All other operations must be performed by trained service personnel. Observe safety precautions in this manual, on tags, and labels attached to the furnace and other safety precautions that may apply.

Recognize safety information. This is the safety-alert symbol . When you see this symbol on the furnace and in instructions or manuals, be alert to the potential for personal injury.

Understand the signal words DANGER, WARNING, and CAUTION. These words are used with the safety-alert symbol. DANGER identifies the most serious hazards which **will** result in severe personal injury or death. WARNING signifies hazards which **could** result in personal injury or death. CAUTION is used to identify unsafe practices which **would** result in minor personal injury or product and property damage.

STARTING YOUR FURNACE

Instead of a continuously burning pilot flame which wastes valuable energy, your furnace uses an automatic, hot surface ignition system to light the burners each time the thermostat turns on your furnace. **Follow these important safeguards:**

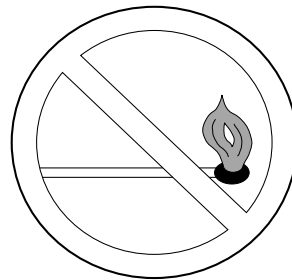

7

- Never attempt to light the burners manually with a match or other source of flame.
- Read and follow the operating instructions on the furnace, especially the item that reads as follows:

Wait 5 minutes to clear out any gas. Then smell for gas, including near the floor. If you smell gas, **STOP!** Follow "B" in the safety information above on this label. If you don't smell gas, go to the next step.

- If a suspected malfunction occurs with your gas control system, such as the burners not lighting when they should, refer to the shutdown procedures on the furnace, or in the section, “Shutting Down Your Furnace” and call your dealer as soon as possible.

⚠ WARNING

If overheating occurs or the gas valve fails to shut off the gas supply, turn off the manual gas valve to the furnace BEFORE turning off the electrical supply. (See Fig. 9.) Failure to follow this warning could result in a fire or explosion, and personal injury or death.

CHECK AIR FILTER: Before attempting to start your furnace, be sure the furnace filter is clean and in place. See section “Performing Routine Maintenance” in this manual. Then proceed as follows:

STEPS FOR STARTING YOUR FURNACE

1. Set your room thermostat to the lowest temperature setting. (See Fig. 8.)
2. Close the external manual gas valve. (See Fig. 9.)
3. Turn off electrical supply to the furnace. (See Fig. 10.)

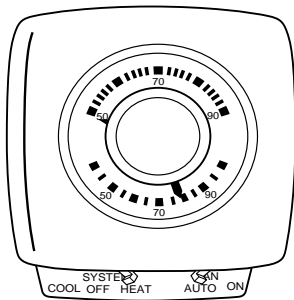

8

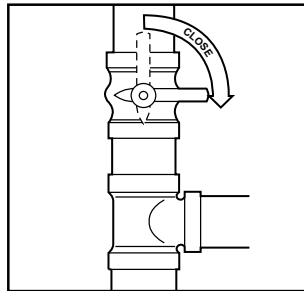

9

4. Remove the furnace access door. (See Fig. 11.)
5. Turn control knob on the gas valve to the OFF position and wait 5 minutes. Then smell for gas, including near the floor. If you smell gas, **STOP!** Follow operating instructions on furnace access door. (See Fig. 12.)
6. After waiting 5 minutes, turn control knob on the gas valve to the ON position. (See Fig. 12.)
7. Replace furnace access door. (See Fig. 13.)
8. Turn on electrical supply to the furnace and wait 1 minute. (See Fig. 14.)
9. Open the external manual gas valve. (See Fig. 15.)
10. Set room thermostat to a temperature slightly above room temperature. This will automatically signal the furnace to start.

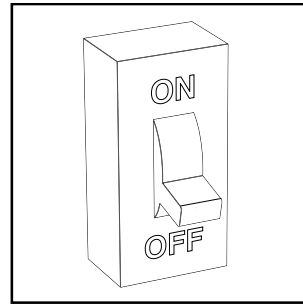

10

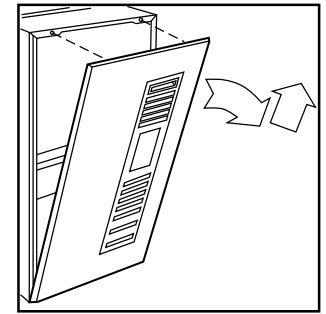

11

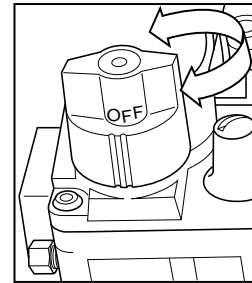

12

NOTE: If the burners fail to ignite after 4 attempts, the furnace control system will lockout. If lockout occurs, main burners fail to light, or blower does not come on, shut down the furnace and call your dealer for service.

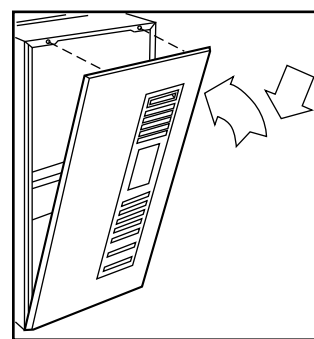

13

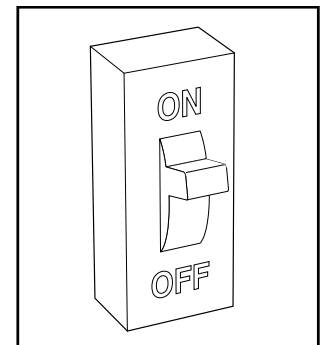

14

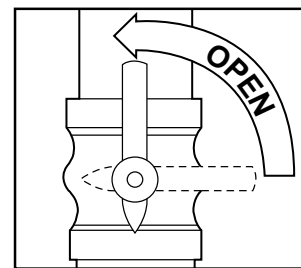

15

11. When the furnace receives the start signal, the hot surface ignitor at the main burners is automatically heated for 15 to 20 sec. When the microprocessor control verifies that there is sufficient heat to ignite, the gas valve permits gas to flow to the main burners. After ignition and a time delay of about 35 sec, your blower will start at low speed until the control makes the necessary adjustments to operate the blower at either the low- or high-fire speed.

12. Set your thermostat to the temperature that satisfies your comfort requirements. **SUGGESTION:** Setting the thermostat back a few degrees and compensating for the difference with warmer clothing can make a big difference in your fuel consumption on extremely cold days. The few degrees at the top of your thermostat “comfort level” are the most costly degrees to obtain.

When room temperature drops below the temperature selected on the thermostat, the furnace will be switched on automatically. When room temperature reaches the degree selected on the thermostat, the furnace will be switched off automatically.

Some thermostats have a FAN switch with 2 selections, AUTO and ON. When thermostat is set to AUTO, the furnace blower cycles on and off, controlled by the thermostat. In ON position, the furnace blower runs continuously. This keeps the temperature level in your home more evenly balanced. It also continuously filters the indoor air.

SHUTTING DOWN YOUR FURNACE

Should you need to shut down your furnace for service or maintenance, you will need to turn the furnace off. The following procedures must be followed:

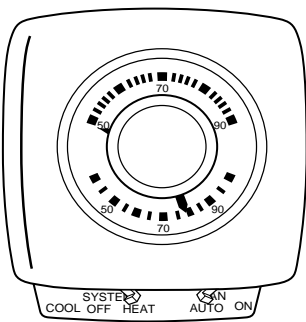

16

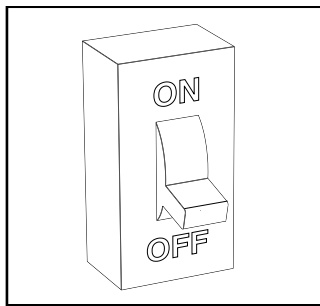

17

1. Set your room thermostat to the lowest temperature setting. (See Fig. 16.)
2. Close the external manual gas valve. (See Fig. 9.)
3. Turn off electrical supply to the furnace. (See Fig. 17.)
4. Remove furnace access door. (See Fig. 11.)
5. Turn control knob on the gas valve to OFF position. (See Fig. 18.)
6. Replace furnace access door. (See Fig. 13.)
7. If the furnace is being shut down because of a malfunction, call your dealer as soon as possible.

⚠ CAUTION

Furnace is not to be installed, operated, and then turned off and left turned off in an unoccupied structure during winter. (See winterizing procedures in maintenance section).

PERFORMING ROUTINE MAINTENANCE

With proper maintenance and care, your furnace will operate economically and dependably. Instructions for basic maintenance, which can easily be followed, are found on this and the following pages. However, before beginning maintenance, follow these safety precautions:

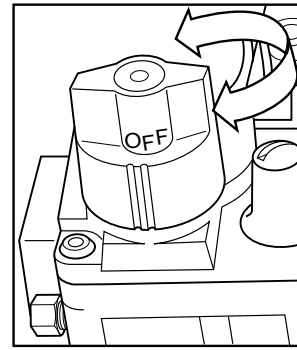

⚠ WARNING

Turn off electrical power supply to your furnace before removing the access door to service or perform maintenance. Failure to follow this warning could result in personal injury or death.

⚠ CAUTION

Although special care has been taken to minimize sharp edges, be extremely careful when handling parts or reaching into the furnace.

FILTERING OUT TROUBLE

A dirty filter will cause a loss of airflow in your duct system. When excessive loss of airflow occurs, the furnace may cycle on the safety controls. If this condition is left unattended, the furnace will eventually lockout. It is recommended that the furnace filter be checked every 3 or 4 weeks and cleaned if necessary.

⚠ CAUTION

Never operate your furnace without a filter in place. Doing so may damage the furnace blower motor. An accumulation of dust and lint on internal parts of your furnace can cause a loss of efficiency.

The air filter is normally located in the blower compartment. (See Fig. 3 or 4.) If filter has been installed in another location, contact your dealer for instructions. To inspect, clean and/or replace the air filter(s), follow these steps:

1. Turn off electrical supply to the furnace. (See Fig. 17.)
2. Remove furnace access door. (See Fig. 19.)
3. Remove blower access panel. (See Fig. 20.)

NOTE: It will be necessary to remove 1 screw.

• FILTER(S) LOCATED IN BOTTOM:

1. Slide filter retainer sideways until it is free of latch. (See Fig. 21 and 22.)

• FILTER LOCATED IN SIDE:

1. Remove filter retainer from latch. (See Fig. 23.)
2. Gently remove filter and carefully turn the dirty side up (if dirty) to avoid spilling dirt from the filter. (See Fig. 24.)
3. Inspect the filter. If torn, replace it.

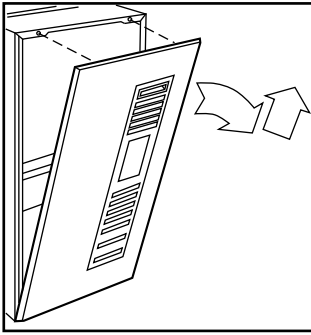

19

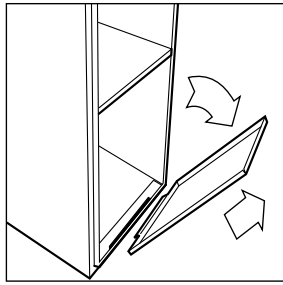

20

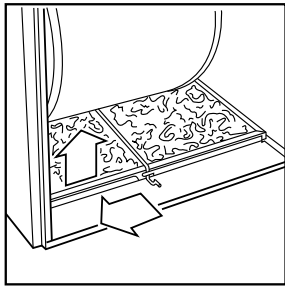

21

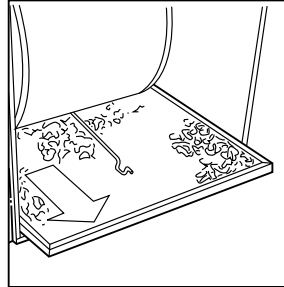

22

NOTE: If washable filter that was shipped with the furnace has been replaced with an electronic air cleaner (EAC), refer to the EAC Owner's Manual for maintenance information.

4. Wash filter (if dirty) in a sink, bathtub, or outside with a garden hose. Always use cold tap water. A mild liquid detergent may be used if necessary. Spray water through filter in the opposite direction of airflow. Allow filter to dry.
5. Reinstall clean filter.
6. Reinstall filter retainer.
7. Replace blower and control access panels and turn on electrical supply to the furnace. (See Fig. 25 and 26.)

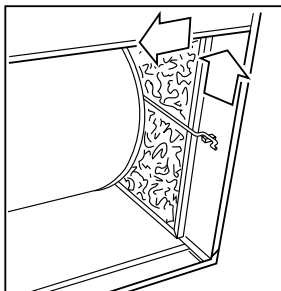

23

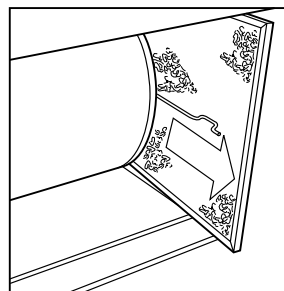

24

If your furnace filter needs to be replaced, be sure to use the same size and type of filter that was originally supplied. Use the furnace filter table and compare your furnace size with the proper filter size.

FURNACE FILTER TABLE

FURNACE CASING WIDTH (IN.)	FILTER SIZE* (IN.)	FILTER TYPE
17-1/2	(1) 16 x 25 x 1	Cleanable
21	(1) 20 x 25 x 1	Cleanable
24-1/2	(2) 16 x 25 x 1	Cleanable

* Furnace with a side return-air inlet may have a different filter size. Measure the filter to obtain the correct size.

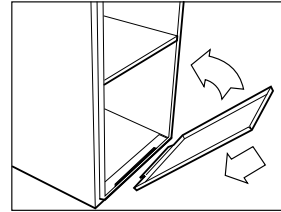

25

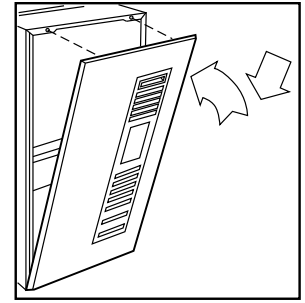

26

COMBUSTION AREA AND VENT SYSTEM

Visually inspect the combustion area and vent system before each heating season. Make sure that all PVC pipes leading into the combustion area and vent are free from any cracks and sags. Also check the combustion-air intake and vent pipes on the outside of your home for blockage.

When dirt, soot, scale or rust is allowed to build up, your furnace can suffer a loss of efficiency and perform improperly. Accumulations on the main burners can result in firing out of normal sequence. This delayed ignition creates an alarmingly loud sound.

⚠ CAUTION

If your furnace makes an especially loud noise when the main burners light, shut down your furnace and call your dealer.

To inspect the combustion area and vent system, you will need a flashlight. Refer to Fig. 3 or 4, and proceed as follows:

1. Turn off gas and electrical supplies to the furnace and remove the access door. (See Fig. 9, 10, and 11.)
2. Remove burner enclosure front. (See Fig. 27 or 28.)

Inspect the gas burners and ignitor area for dirt, rust, or scale.

⚠ CAUTION

If dirt, rust, soot, or scale accumulations are found, call your dealer. Do not operate your furnace.

3. Inspect the combustion-air and vent pipes for sags, holes, cracks, or disconnections.

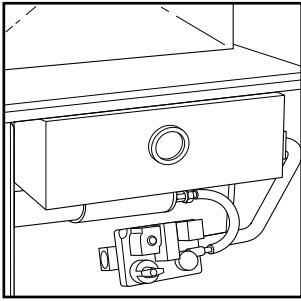

27

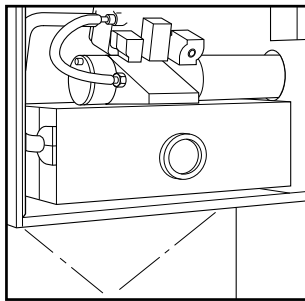

28

⚠ DANGER

If holes are found in the pipes or if any portion has become disconnected, toxic fumes can escape into your home. **DO NOT OPERATE YOUR FURNACE.** Call your dealer for service.

4. Reinstall burner enclosure front.
5. If your furnace is free of the above conditions, replace access door and turn on electrical and gas supplies to the furnace. (See Fig. 13, 14, and 15.)
6. Start the furnace and observe its operation. Watch the burner flames to see if they are clear blue, almost transparent. (See Fig. 29.) If you observe a suspected malfunction, or the burner flames are not clear blue, call your dealer.

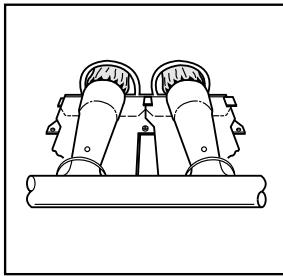

29

HEADING SOUTH FOR THE WINTER?

DON'T FORGET YOUR FURNACE!

⚠ CAUTION

If the furnace is installed in an unconditioned space where the ambient temperatures may be 32°F or lower, freeze protection measures must be taken.

Since the furnace uses a condensing heat exchanger, some water will accumulate in the unit as a result of the heat transfer process. Therefore, once it has been operated, it cannot be turned off and left off for an extended period of time when temperatures will reach 32°F or lower unless winterized. Follow these procedures to winterize your furnace:

1. Obtain propylene glycol (RV/swimming pool anti-freeze or equivalent)

⚠ CAUTION

Do not use ethylene glycol (Prestone II antifreeze coolant or equivalent). Failure of plastic components will occur.

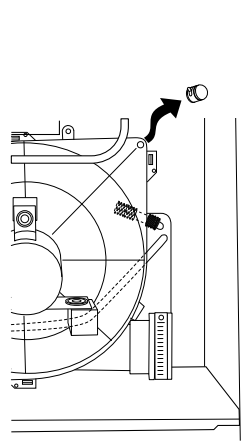

30

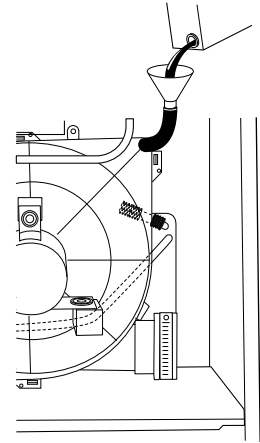

31

2. Turn off electrical supply to the furnace. (See Fig. 17.)
3. Remove furnace access door. (See Fig. 19.)
4. Remove upper inducer housing drain connection cap. (See Fig. 30.)
5. Connect field-supplied 1/2-in. ID tube to upper inducer housing drain connection.
6. Insert field-supplied funnel into tube.
7. Pour 1 quart of antifreeze into funnel/tube. Antifreeze should run through inducer housing, overflow condensate trap, and flow into open field drain. (See Fig. 31.)
8. Remove funnel and tube from inducer housing and replace drain connection cap and clamp.
9. Replace furnace access door. (See Fig. 26.)

A CHECKUP CHECKLIST

Your furnace represents an important investment in your family's comfort and your home's value. To keep it performing properly and as a preventative to future problems, have a trained service specialist give your furnace a professional check-up annually. The following checklist can be used as a guideline to proper service:

- Inspect all flue gas passages, burners, heat exchangers, coupling box(es), and inducer assembly.
 - Inspect all combustion-air and vent piping inside structure and pipe terminations outside the structure.
 - Check gas pipes leading to and inside of your furnace for leaks.
 - Inspect and clean the blower motor and wheel.
- NOTE:** The inducer and blower motors are pre-lubricated and require no additional lubrication. These motors can be identified by the absence of oil ports on each end of the motor.
- Inspect and change or clean air filter(s) if necessary.
 - Inspect all supply- and return-air ducts for obstructions, air leaks, and insulation. Remedy any problem when necessary.

- Inspect the return-air duct connection(s) at the furnace to ensure it is physically sound, sealed to the furnace casing, and terminates outside the space containing the furnace.
- Inspect electrical wiring, connections, and components for loose connections.
- Perform an operational checkout to determine whether your furnace is working properly and if it requires adjustments.
- Inspect all condensate drain tubes and condensate trap assembly for leaks. The condensate removal system should be cleaned annually by a qualified service agency. Refer to the Service and Maintenance Instructions for further information.
- Examine the physical support of the furnace. Support should be sound with no cracks, sagging, gaps, etc. around the base.
- Check furnace for any obvious signs of deterioration.

BEFORE YOU REQUEST A SERVICE CALL

If your furnace is not operating or not performing properly, you may save the expense of a service call by checking a few things yourself before calling for service.

FOR INSUFFICIENT AIRFLOW:

- Check for dirty air filter(s).
- Check for blocked return-air or supply-air grilles throughout your home. Ensure they are open and unobstructed.

If problem still exists, call your dealer for service.

IF FURNACE FAILS TO OPERATE:

Follow this checklist step by step, advancing to the next step only if furnace fails to start.

- Check thermostat for proper temperature. Is thermostat set above room temperature?

- Is thermostat switch on HEAT?
- Check fuses and circuit breakers. Is electrical supply on?
- Is manual shut-off valve in gas supply pipe in open position? (Follow start-up procedures if you open gas valve.)

NOTE: Turn off electrical supply before continuing with checklist.

- Is control knob on gas valve in ON position? (Follow start-up procedures if you must reset knob to ON.)
- Check manual reset flame rollout switch located on the burner box. (See Fig. 2 or 3.) If furnace has experienced high temperature conditions, this switch will shut off the furnace. Reset it by pushing the button on the switch. If it trips again, shut down the furnace and call for service. See section “Shutting Down Your Furnace” in this manual.
- Check for obstructions around the vent termination.

If the furnace still fails to operate, call your service representative.

For your convenience, record the furnace product and serial numbers on page 2. Should you ever require service, you will have ready access to the information needed by your service representative.

This furnace has an LED operation and fault code display to aid the installer, service technician, or homeowner while installing or servicing the unit. The LED code can be seen by removing the access door and viewing the LED(s) through the view port in the blower access panel.

NOTE: Removing the blower access panel or turning off the 115-v electrical power supply will terminate LED diagnostic code display.

To decipher the meaning of the LED code, and suggested action, the following cross-reference can be used.

MODEL 58MCA and 58MXA DIAGNOSTIC CHART

(See Fig. 3.)

FAULT CODE	FAULT CODE DESCRIPTION	CHECKLIST
13 or 33	Limit Switch Lockout	<input type="checkbox"/> Check for dirty air filter. <input type="checkbox"/> Check for blocked return-air or supply-air grilles.
14 or 34	Ignition Lockout or Ignition Proving Fault	<input type="checkbox"/> Check to be sure manual shut-off valve in gas supply pipe is in the open position. (Follow start-up procedure if you open gas line.) NOTE: Turn off the electrical supply and remove access doors before continuing with this checklist. <input type="checkbox"/> Check to be sure control knob on gas valve is in ON position. (Follow start-up procedures if you must reset dial to ON.)
24	Furnace Fuse Open	<input type="checkbox"/> Check for blown fuse and possible short in 24-v wiring.
31	Pressure Switch Not Closed	<input type="checkbox"/> Check to make sure that all PVC pipes leading into the combustion-air intake and vent/exhaust are free from any cracks and sags. Also check the combustion-air intake and vent/exhaust pipes on the outside of your home for blockage.
12, 21, 22, or 23	Any Other Fault Code	<input type="checkbox"/> Call dealer for service.
No Fault Code Signaled	Furnace Fails to Operate and No Fault is Signaled	<input type="checkbox"/> Check thermostat for proper temperature setting. <input type="checkbox"/> Check for blown fuses and circuit breakers. <input type="checkbox"/> Check to be sure blower access panel is properly in place.

NOTES:

1. Light on continuously means control has power and working properly.
2. The status codes are a 2 digit number. The first digit is determined by the number of short flashes of the light and the second digit is determined by number of

MODEL 58MVP DIAGNOSTIC CHART

(See Fig. 4.)

FAULT CODE	FAULT CODE DESCRIPTION	CHECKLIST
12	Blower Calibration Lockout	<input type="checkbox"/> Check for dirty air filter.
13 or 33	Limit Switch Lockout	<input type="checkbox"/> Check for blocked return-air or supply-air grilles. <input type="checkbox"/> Turn electrical supply off, then back on. Set the thermostat switch to call for heat.
14 or 34	Ignition Lockout or Ignition Proving Fault	<input type="checkbox"/> Check to be sure manual shut-off valve in gas supply pipe is in open position. (Follow start-up procedure if you open gas line.) NOTE: Turn off the electrical supply and remove access doors before continuing with this checklist. <input type="checkbox"/> Check to be sure control knob on gas valve is in ON position. (Follow start-up procedures if you must reset dial to ON). <input type="checkbox"/> Check for disconnected ground wire.
24	Furnace Fuse Open	<input type="checkbox"/> Check for blown fuse and possible short in 24-v wiring.
31, 32, or 43	Pressure Switch Fault	<input type="checkbox"/> Check to make sure that all PVC pipes leading into the combustion-air intake and vent/exhaust are free from any cracks and sags. Also check the combustion-air intake and vent/exhaust pipes on the outside of your home for blockage.
42	Inducer Outside Valid Speed Range	
44	Blower Calibration Fault	<input type="checkbox"/> Check for dirty air filter(s). <input type="checkbox"/> Check for blocked return- or supply-air grilles. NOTE: In zoned applications, fault 44 may flash during operation when a single zone is calling for heat. When other zones call for heat, or the unit cycles, the fault should clear itself. Call for service if fault 12 develops.
21, 22, 23, or 41	Any Other Fault Code or Either of the Red Lights On Continuously	<input type="checkbox"/> Call dealer for service.
No Fault Code Signaled	Furnace Fails to Operate and No Fault is Signaled	<input type="checkbox"/> Check thermostat for proper temperature setting. <input type="checkbox"/> Be sure thermostat switch is on HEAT. <input type="checkbox"/> Check for blown fuses and circuit breakers. <input type="checkbox"/> Check to be sure blower access panel is properly in place.

NOTES:

1. Red light 1 on continuously means furnace is operating in emergency heat.
2. Red light 2 on continuously means the microprocessor board has malfunctioned.
3. Yellow light on continuously means furnace is operating in high heat.
4. Green light on continuously means furnace is operating in low heat.
5. The status codes are a 2 digit number. The first digit is determined by the number of flashes of the yellow light and the second digit is determined by number of flashes of the green light.



TO OBTAIN INFORMATION ON PARTS: Consult your installing dealer or classified section of your local telephone directory under the "Heating Equipment" or "Air Conditioning Contractors & Systems" headings for dealer listing by brand name. Have available the Model No., Series Letter & Serial No. of your equipment to insure correct replacement part.

Carrier Corporation • Syracuse, New York 13221

Manufacturer reserves the right to discontinue, or change at any time, specifications or designs without notice and without incurring obligations.